

## Product description

### PK couplings

The INKOMA-PK coupling is machine component designed to transmit torque between axially parallel, radially offset shafts. The coupling permits both static and dynamic stepless adjustment of radial offset within the designed adjustment range.

The coupling functions on a parallel crank principle (similar to the traditional draughting mechanism). Each movement at the input is faithfully repeated at the output, without loss or change.

No relative motion occurs regardless of the degree of offset, unlike a universal joint assembly. The INKOMA-PK coupling comprises three discs with their faces parallel to each other, connected by at least 3 links.

One outer disc is connected to the input shaft and the other to the output shaft. The centre disc provides the connection, via the links, to the outer discs.

#### Features of the INKOMA-PK coupling

The INKOMA-PK coupling has synchronous running characteristics; i.e. the input and output run totally synchronously with no angular displacement, regardless of the degree of offset.

The INKOMA-PK coupling is dynamically balanced and damps and compensates for radial vibrations imposed from outside the drive.

The INKOMA-PK coupling transmits purely torque and therefore imposes no radial loads on related bearings.

The INKOMA-PK coupling requires very little space when compared with the offset capability.

The INKOMA-PK coupling will tolerate all radial offsets, lying within the designed capability of the coupling. Within the limiting values the radial offset can be freely adjusted whilst transmitting torque loads and at any speed. The angular velocities remain completely synchronous between input and output.

Special sizes and designs are possible. Please enquire.

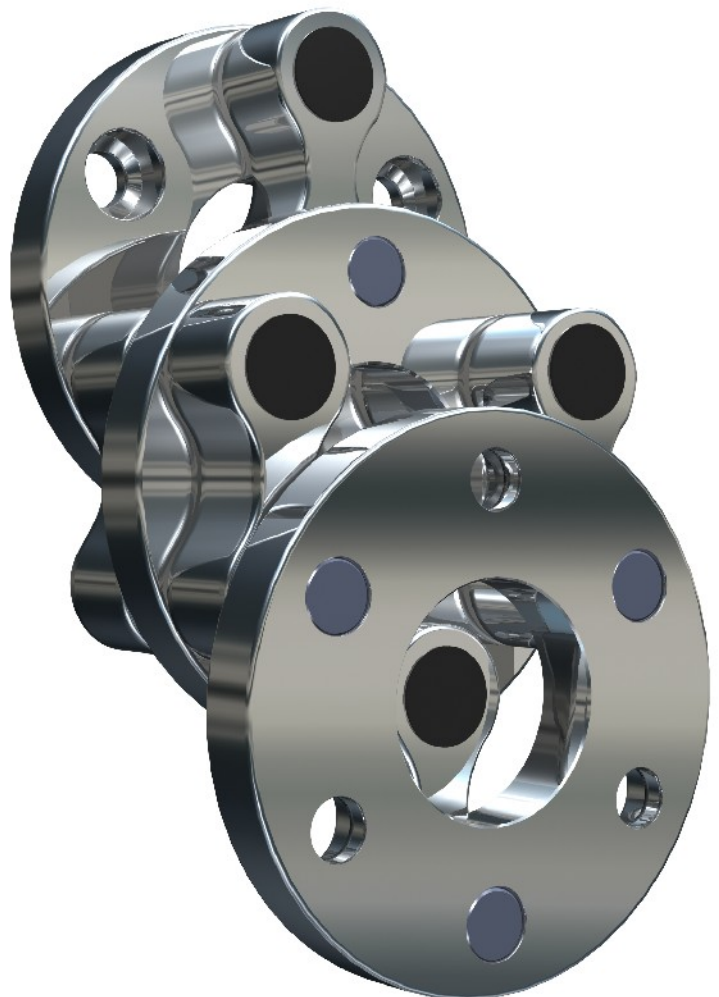

## Contents list

### PK couplings

		<b>Technical information</b>	Page
		versions A1, A2, A3, A4, A7 notes for installation and operation lubrication for PK coupling	003 - 005
<hr/>			
		<b>Dimensions NA 44 - NA 196</b>	Page
		arrangement and permissible operating range PK coupling (A1, A2, A3, A4, A7)	006 - 009
<hr/>			
		<b>Selection table</b>	Page
		torque based life selection table power based life selection table	010 - 011
<hr/>			
		<b>Dimension NA 280 - NAS 600 (heavy series)</b>	Page
		PK coupling (A1, A2, A4, A7)	012 - 013
<hr/>			
		<b>Dimension GLK, GL (light series, plain bearing)</b>	Page
		PK coupling	014 - 015
<hr/>			
		<b>Dimensions for GFL - separable flange</b>	Page
		for version A4.	016 - 017
<hr/>			
		<b>Dimensions for ISP-B - Inkofix tension flange</b>	Page
		For version A3.	018 - 019
<hr/>			
	1. <input type="checkbox"/> <input type="checkbox"/> <input type="checkbox"/> <input type="checkbox"/> 2. .... 3. <input type="checkbox"/> ..... <input type="checkbox"/> ..... ...	<b>Questionnaire</b>	Page
		for quotation purpose	020
<hr/>			

## Technical information

### PK couplings

INKOMA-PK coupling is available in the following versions:

**A1 = Basic version:**

Both outer discs have fixing holes for socket head cap screws for connecting components. The number of fixing holes on pitch circle "C":

- 3 Links= 3 x 120°
- 4 Links= 4 x 90°
- 5 Links= 5 x 72°
- 6 Links= 6 x 60°

**A2 = Hub version:**

Both outer discs have machined hubs.

**A3 = Tension hub version:**

Basic version A1 with additional shrink disc. The shrink disc allows keyless fitting to the shaft.

For details of the tension flange see page 18.

**A4 = Separable hub version:**

Basic version A1 with additional adaptor flanges. These flanges have hubs for shaft fitting.

For details of separable flanges see page 16.

**A7 = Split hub version:**

This hub version has two components - a fixed and a removable part allowing radial clamping to the shaft. This version requires no axial displacement of the shaft for assembly and disassembly.

**Combinations:**

Each coupling can combine any of these versions. E.g. A1/A2 - one disc with fixing holes and the other with outward facing bored hub.

All versions may be combined with one another, e.g. A3/A4, A1/A4, A2/A3

**Special versions:**

In addition to basic versions, customer specific executions are also possible e.g. incorporating sprocket, gears, shaft, etc. in the outer discs.

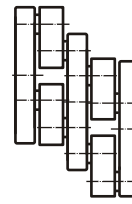

A1 A1

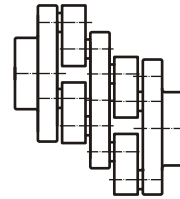

A2 A2

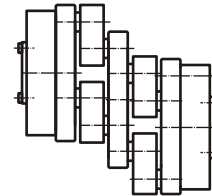

A3 A3

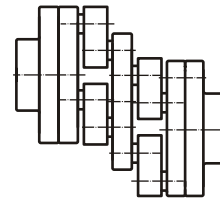

A4 A4

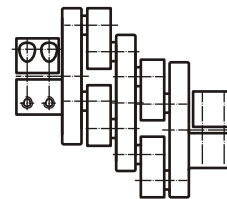

A7 A7

**Position of the centre disc:**

Example: NA 74.36.70/3 Offset Y= 20 mm, L<sub>1</sub>= 36 mm

$$x = \sqrt{\left(\frac{L_1}{2}\right)^2 - \left(\frac{Y}{2}\right)^2}$$

$$x = \sqrt{\left(\frac{36 \text{ mm}}{2}\right)^2 - \left(\frac{20 \text{ mm}}{2}\right)^2} = 14.97 \text{ mm}$$

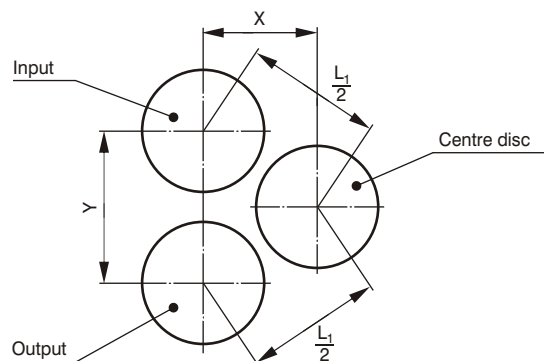

## Technical information

### PK couplings

#### Notes for installation and operation:

The shafts to be connected must have their centre lines parallel to one another. If the specified max. possible angularity  $\sphericalangle \alpha^\circ$  is exceeded the use of an INKOMA-Inkoflex coupling is recommended. (see catalogue Inkoflex couplings). An inclination of the shafts towards each other leads to edge loading of the bearings and premature wear and failure.

#### All PK couplings have axial freedom:

Light series	- Plain bearing coupling	+ 2 mm
Standard series	- up to size NA 196	$\pm 2$ mm
Heavy series	- up to size NAS 600	$\pm 4$ mm

Ensure that the coupling is not axially tensioned in assembly; the centre disc should feel axially free.

Care should be taken to ensure the coupling does not run with the links in tension (stretched). It is possible that the links can be stretched leading to bearing failure. In addition this can lead to the centre disc taking a different sense of rotation when reversing.

Max. permitted working offset  $0,95 \cdot$  limit of displacement. This should be limited by an end stop.

The two outer discs should not be run directly in line.

A minimum value of  $0,25 \cdot$  limit of displacement should be maintained. When in line the centre disc is no longer stable.

The coupling is supplied ready for use. The needle roller bearings supporting the links are adequately lubricated. Re-greasing can be carried out using grease nipples. Under normal operating conditions the coupling is lubricated for life. See page 5 for exceptions.

Despite the most precise manufacturing procedures and the use of the highest quality materials and bearings a small amount of play is present. In the adjacent diagram empirically derived values for average torsional stiffness are shown.

If a complete absence of backlash is demanded we suggest using pre-loading or drag effects. In most applications the torsional values are adequate.

The INKOMA-PK coupling is dynamically balanced and damps and compensates for radial vibrations imposed from outside the drive.

#### Application examples:

There are many applications for the INKOMA-PK coupling. A few typical cases are described below.

#### Drive for rollers:

Two related rollers must run synchronously even when the axes are being adjusted for varying products.

#### Haul off:

Drives for two haul-off chains used to pull tubes from a process machine. Both chains must run at precisely the same speed and the gap between them must be adjusted to accommodate different tube diameters.

#### Avoidance of conflict:

For design reasons the shafts must avoid a conflict. INKOMA-PK coupling provides a simple and space saving solution.

#### Oscillating drive:

INKOMA-PK couplings are successfully used where both the driving and driven shafts must achieve variations in their position and relationship to each other. To demonstrate the breadth of applications for INKOMA-PK coupling see the following list of machine types.:

Filling machines, press lines, printing machines, labelling machines, pleating machines, glass tube drawing, woodworking machines, adhesive sealing machines, roller coating, oscillating drives, paper machinery, roller inspection, actuators, textile machinery, steering systems, packaging machinery, machine tools, cigarette machinery.

## Technical information

### PK couplings

#### Lubrication for PK coupling:

The coupling is supplied ready for operation. Re-lubrication can be carried out using the grease nipples fitted to the links. Re-lubrication frequency depends on the grease characteristics (and grease type), operating temperature, speed, load, amount of grease and environmental conditions. These factors must be observed since they can result in considerable differences.

Values for relubrication intervals are expressed in the number of operating hours after which topping up or relubrication is required for that situation. Generally it may be assumed that, in normal operating conditions (moderate loading) life time lubrication is provided.

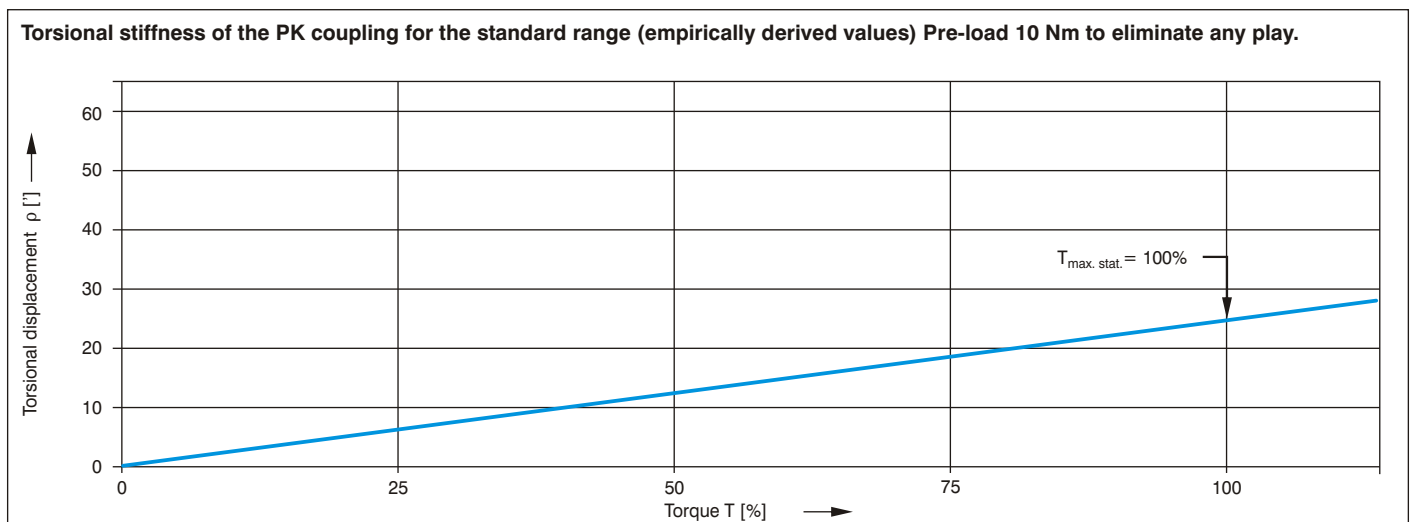
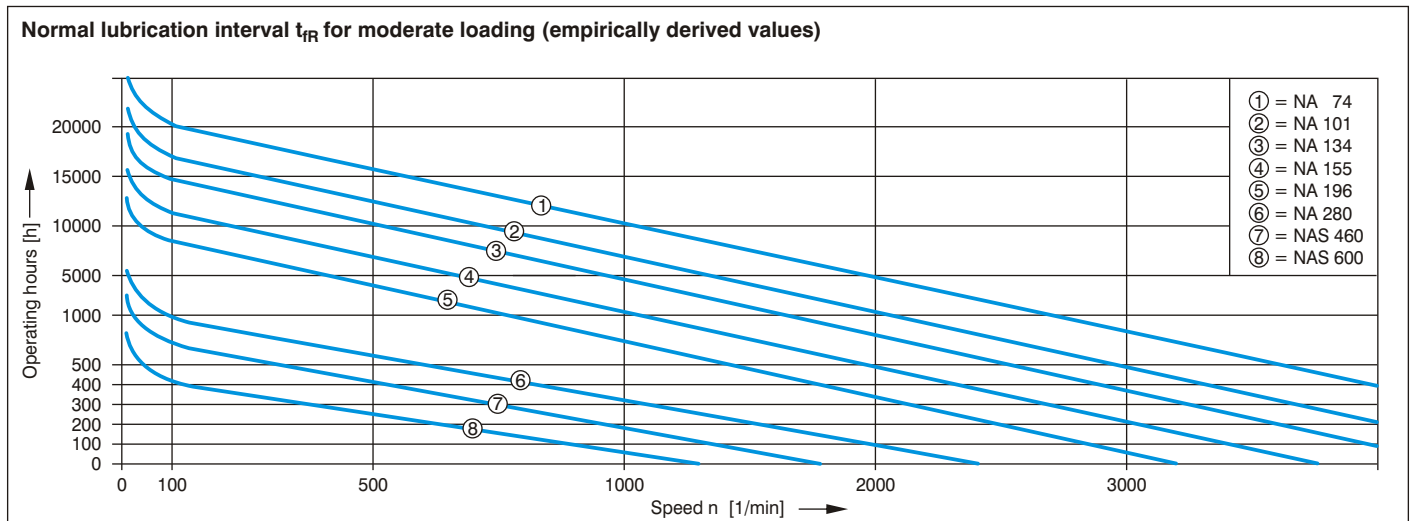

## Dimensions NA 44 - NA 196

### PK couplings

#### Arrangement and permissible operating range:

- 1) Driving shaft
- 2) Driven shaft
- 3) Outer disc (Version A2 with integral hub)
- 4) Centre disc
- 5) Outer disc (Version A1, for connecting with a separable flange)
- 6) Separable flange
- 7) Cap head screws DIN 7984 and DIN 6912 (not supplied)
- 8) Grease nipple

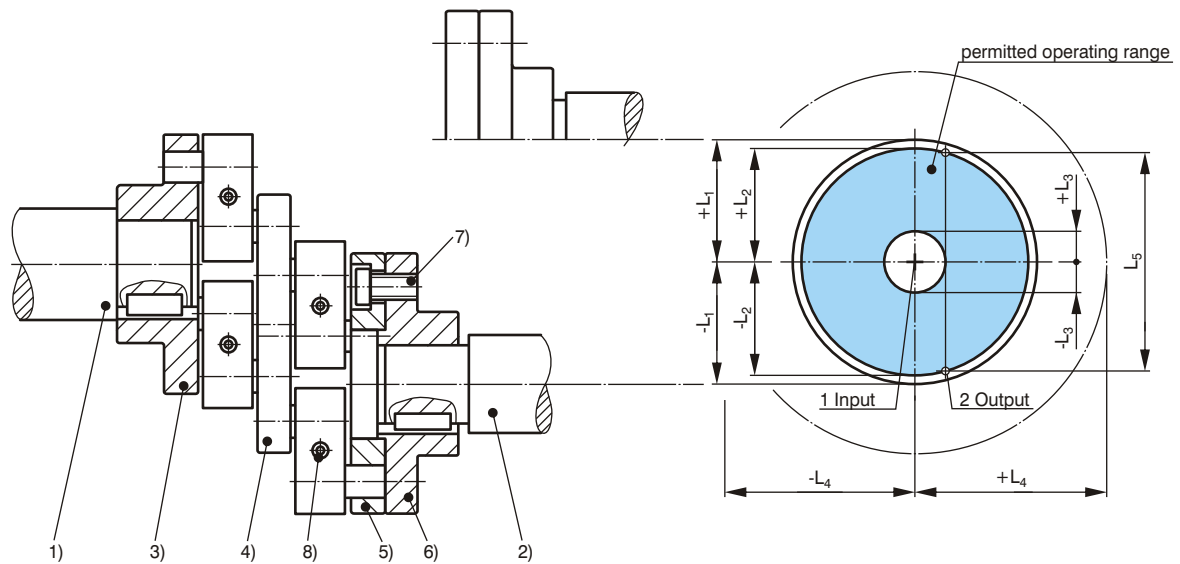

- $L_1$  limit of displacement
- $L_2$  permitted operating range
- $L_3$  minimum offset
- $L_4$  max. displacement of centre flange
- $L_5$  max. tangential working offset

#### Ordering example:

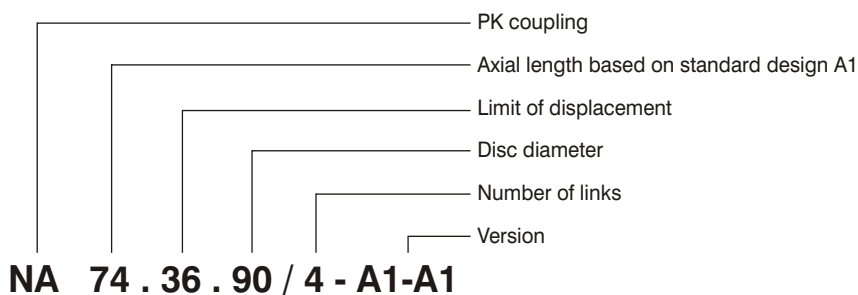

## Dimensions NA 44 - NA 196

### PK coupling (A1, A2, A3, A4, A7)

INKOMA-PK coupling is available in the following versions:

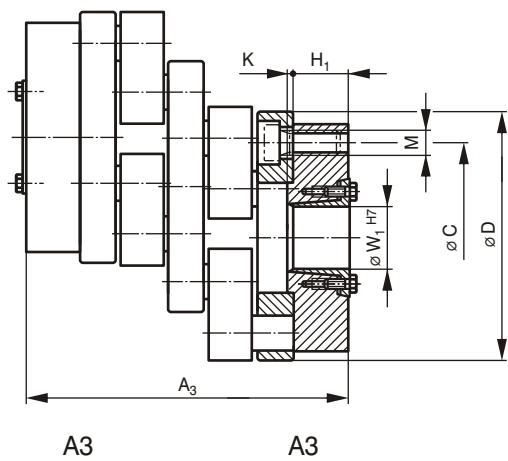
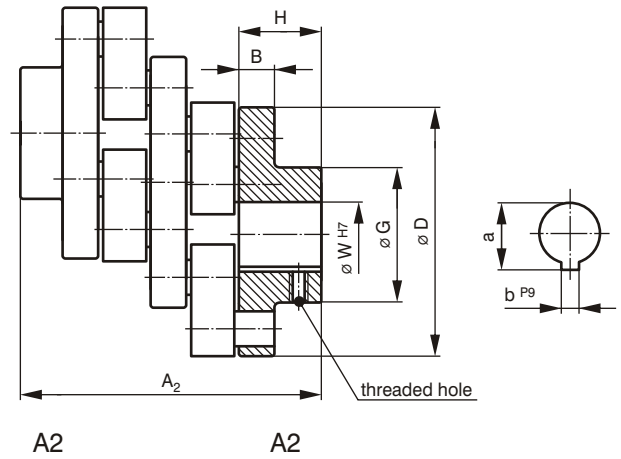
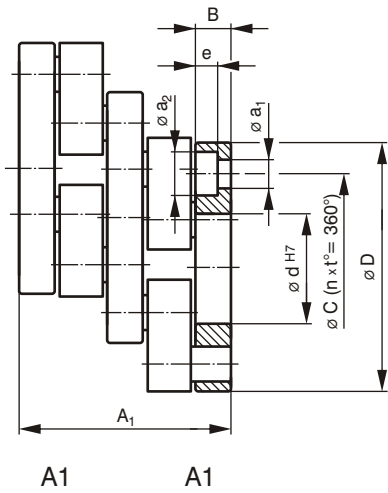

$$A3 = A1 + ISP-B$$

For further details see page 18 tension flange.

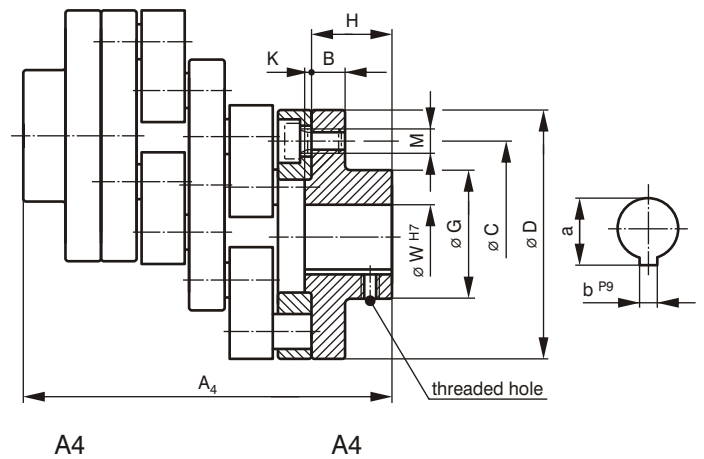

$$A4 = A1 + GFL$$

For missing dimensions and designations for GFL see page 16.

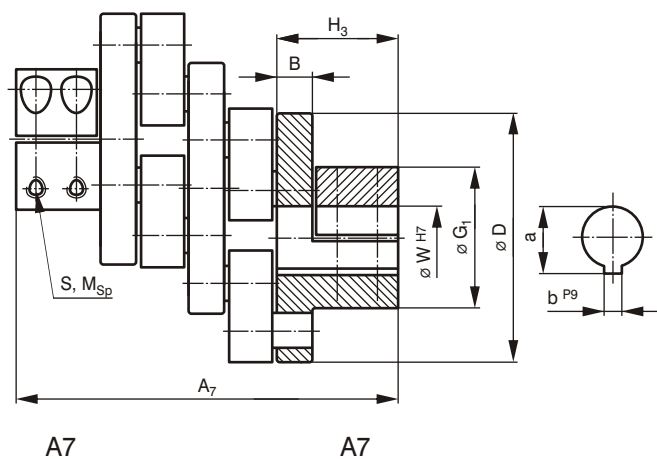





## Operational data NA 44 - NA 196

### PK coupling (A1, A2, A3, A4, A7)

Order code	Dimensions [mm]					Mounting holes			Clamping screw A7		Operational data			CAD-No.:
	limit of displacement L <sub>1</sub>	permitted operating range L <sub>2</sub>	minimum offset L <sub>3</sub>	max. displacement of centre flange L <sub>4</sub>	max. tangential working offset L <sub>5</sub>	Thread M	Number n	Hole pitch t [°]	S	Tightening torque M <sub>Sp</sub> [Nm]	Torque T <sub>stat.</sub> [Nm]	Inertia <sup>5)</sup> J [kg cm <sup>2</sup> ]	Mass <sup>5)</sup> [kg]	
NA 44.25.50/3 1)	25	23,5	5,5	38	45	M6	3	120	2xM5	6	34	1,2	0,4	31001
NA 44.25.50/4 1)	25	23,5	5,5	38	45	M6	4	90	2xM5	6	45	1,5	0,5	31007
NA 44.25.70/6 1)	25	23,5	5,5	58	45	M6	6	60	4xM5	6	110	2,7	0,6	31004
NA 74.36.70/3	36	34	9	53	65	M8	3	120	4xM5	6	105	4,9	0,8	31101
NA 74.36.90/3	36	34	9	63	65	M8	3	120	4xM6	10,5	153	15	1,5	31104
NA 74.70.90/3	70	67	17,5	80	126	M8	3	120	4xM6	10,5	153	16	1,6	31107
NA 74.36.90/4	36	34	9	63	65	M8	4	90	4xM6	10,5	203	16	1,6	31110
NA 74.36.90/5	36	34	9	63	65	M8	5	72	4xM6	10,5	255	16	1,6	31137
NA 74.120.120/3	120	114	30	120	216	M8	3	120	4xM8	25	213	53	2,9	31113
NA 74.36.120/4	36	34	9	78	65	M8	4	90	4xM8	25	285	52	2,9	31116
NA 74.70.120/4	70	67	17,5	95	126	M8	4	90	4xM8	25	285	52	2,9	31119
NA 74.36.150/4	36	34	9	93	65	M8	4	90	4xM8	25	372	118	4,2	31122
NA 74.70.150/4	70	67	17,5	110	126	M8	4	90	4xM8	25	372	121	4,3	31125
NA 74.120.150/4	120	114	30	135	216	M8	4	90	4xM8	25	372	127	4,5	31128
NA 101.56.100/3	56	53	14	68	100	M12	3	120	4xM8	25	425	43	3,4	31301
NA 101.56.120/3	56	53	14	88	100	M12	3	120	4xM8	25	540	72	4,0	31304
NA 101.90.120/3	90	86	22	105	162	M12	3	120	4xM8	25	540	73	4,0	31307
NA 101.56.120/4	56	53	14	88	100	M12	4	90	4xM8	25	729	81	4,5	31310
NA 101.120.140/3	120	114	30	130	216	M12	3	120	4xM10	50	660	154	6,3	31313
NA 101.56.140/4	56	53	14	98	100	M12	4	90	4xM10	50	880	157	6,4	31316
NA 101.90.140/4	90	86	22	115	162	M12	4	90	4xM10	50	880	158	6,4	31319
NA 101.160.160/3	160	152	40	160	288	M12	3	120	4xM12	87	780	246	7,7	31322
NA 101.56.160/4	56	53	14	108	100	M12	4	90	4xM12	87	1040	250	7,8	31325
NA 101.90.160/4	90	86	22	125	162	M12	4	90	4xM12	87	1040	250	7,8	31328
NA 101.120.160/4	120	114	30	140	216	M12	4	90	4xM12	87	1040	250	7,8	31331
NA 134.64.140/3	64	61	16	102	115	M16	3	120	4xM10	50	1178	213	8,7	31501
NA 134.90.140/3	90	86	22	115	162	M16	3	120	4xM10	50	1178	225	9,2	31504
NA 134.64.160/3	64	61	16	112	115	M16	3	120	4xM12	87	1413	278	8,7	31507
NA 134.90.160/3	90	86	22	125	162	M16	3	120	4xM12	87	1413	294	9,2	31510
NA 134.120.160/3	120	114	30	140	216	M16	3	120	4xM12	87	1413	310	9,7	31513
NA 134.64.160/4	64	61	16	112	115	M16	4	90	4xM12	87	1884	310	9,7	31516
NA 134.90.160/4	90	86	22	125	162	M16	4	90	4xM12	87	1884	330	10,3	31519
NA 155.72.160/3	72	68	18	116	130	M16	3	120	4xM12	147	2130	410	12,8	31701
NA 155.72.160/4	72	68	18	116	130	M16	4	90	4xM12	147	2780	438	13,7	31730
NA 155.100.160/3	100	95	25	130	180	M16	3	120	4xM12	147	2130	429	13,4	31704
NA 155.72.180/3	72	68	18	126	130	M16	3	120	4xM12	147	2500	628	15,5	31707
NA 155.100.180/3	100	95	25	140	180	M16	3	120	4xM12	147	2500	631	15,6	31710
NA 155.72.180/4	72	68	18	126	130	M16	4	90	4xM12	147	3335	689	17,0	31713
NA 155.160.200/3	160	152	40	180	288	M16	3	120	4xM12	147	2815	880	17,6	31716
NA 155.72.200/4	72	68	18	136	130	M16	4	90	4xM12	147	3755	870	17,4	31719
NA 155.100.200/4	100	95	25	150	180	M16	4	90	4xM12	147	3755	895	17,9	31722
NA 196.90.200/3	90	86	22,5	145	162	M20	3	120	4xM16	360	8800	1195	23,9	31901
NA 196.150.200/3	150	145	37,5	175	270	M20	3	120	4xM16	360	8800	1280	25,6	31904
NA 196.90.200/4	90	86	22,5	145	162	M20	4	90	4xM16	360	11800	1435	29,3	31907
NA 196.90.250/4	90	86	22,5	170	162	M20	4	90	4xM20	695	15800	2695	34,5	31910
NA 196.150.250/4	150	145	37,5	200	270	M20	4	90	4xM20	695	15800	2875	36,8	31913
NA 196.90.250/5	90	86	22,5	170	162	M20	5	72	4xM20	695	19000	2906	37,2	31916
NA 196.90.250/6	90	86	22,5	170	162	M20	6	60	4xM20	695	23000	3125	40,0	31919
NA 196.90.310/6	90	86	22,5	200	162	M20	6	60	4xM20	695	30000	6667	55,5	31922
NA 196.150.310/6	150	145	37,5	230	270	M20	6	60	4xM20	695	30000	7087	59,0	31925

<sup>5)</sup> for version A1

## Selection table

### Torque based life selection table

Order code	Life $L_h$ [h]															
	1000				5000				10000				20000			
	Speed $n$ [1/min]															
	50	150	500	1500	50	150	500	1500	50	150	500	1500	50	150	500	1500
	Torque $T$ [Nm]															
NA 44.25.50/3	45	32	22	16	28	20	14	10	22	16	11	8	18	13	9	6
NA 44.25.50/4	60	43	30	22	38	27	19	14	30	22	15	11	24	18	12	9
NA 44.25.70/6	144	104	72	52	89	64	44	32	72	52	36	26	58	42	29	21
NA 74.36.70/3	115	81	57	41	70	51	35	25	57	41	28	20	46	33	23	16
NA 74.36.90/3	166	119	83	59	102	73	51	37	83	59	41	30	67	48	34	24
NA 74.70.90/3	166	119	83	59	102	73	51	37	83	59	41	30	67	48	34	24
NA 74.36.90/4	221	159	111	79	136	98	68	49	111	79	55	39	90	64	45	32
NA 74.36.90/5	276	199	138	99	170	122	86	62	139	100	70	50	113	81	57	41
NA 74.120.120/3	232	167	116	83	143	103	71	51	116	83	58	41	94	68	47	34
NA 74.36.120/4	310	223	155	111	191	137	95	68	155	111	77	55	126	90	63	45
NA 74.70.120/4	310	223	155	111	191	137	95	68	155	111	77	55	126	90	63	45
NA 74.36.150/4	405	291	203	145	250	179	125	90	203	145	101	73	164	118	82	59
NA 74.70.150/4	405	291	203	145	250	179	125	90	203	145	101	73	164	118	82	59
NA 74.120.150/4	405	291	203	145	250	179	125	90	203	145	101	73	164	118	82	59
NA 101.56.100/3	396	285	199	142	245	176	122	88	199	142	99	71	161	116	80	58
NA 101.56.120/3	509	367	255	183	314	226	157	113	255	183	127	92	207	149	104	74
NA 101.90.120/3	509	367	255	183	314	226	157	113	255	183	127	92	207	149	104	74
NA 101.56.120/4	679	489	341	244	419	301	209	151	341	244	170	122	276	198	138	99
NA 101.120.140/3	623	448	312	224	384	276	192	138	312	224	156	112	253	182	127	91
NA 101.56.140/4	830	598	416	299	513	368	256	184	416	299	208	149	337	243	169	121
NA 101.90.140/4	830	598	416	299	513	368	256	184	416	299	208	149	337	243	169	121
NA 101.160.160/3	736	530	369	265	454	327	227	163	369	265	184	132	299	215	150	107
NA 101.56.160/4	981	707	492	353	606	436	303	218	492	353	246	177	399	287	200	143
NA 101.90.160/4	981	707	492	353	606	436	303	218	492	353	246	177	399	287	200	143
NA 101.120.160/4	981	707	492	353	606	436	303	218	492	353	246	177	399	287	200	143
NA 134.64.140/3	890	641	446	320	550	395	275	198	446	320	223	160	361	260	181	130
NA 134.90.140/3	890	641	446	320	550	395	275	198	446	320	223	160	361	260	181	130
NA 134.64.160/3	1068	769	536	384	659	474	329	237	536	384	268	192	434	312	217	156
NA 134.90.160/3	1068	769	536	384	659	474	329	237	536	384	268	192	434	312	217	156
NA 134.120.160/3	1068	769	536	384	659	474	329	237	536	384	268	192	434	312	217	156
NA 134.64.160/4	1424	1025	714	512	879	632	439	316	714	512	357	257	578	416	290	208
NA 134.90.160/4	1424	1025	714	512	879	632	439	316	714	512	357	257	578	416	290	208
NA 155.72.160/3	1580	1140	790	570	970	700	480	350	790	570	390	280	640	460	320	230
NA 155.72.160/4	2150	1550	1080	775	1330	955	665	480	1080	775	540	388	876	630	439	316
NA 155.100.160/3	1580	1140	790	570	970	700	480	350	790	570	390	280	640	460	320	230
NA 155.72.180/3	1850	1330	930	660	1140	820	570	410	930	660	460	330	750	540	380	270
NA 155.100.180/3	1850	1330	930	660	1140	820	570	410	930	660	460	330	750	540	380	270
NA 155.72.180/4	2470	1780	1240	890	1530	1100	760	550	1290	890	620	440	1000	720	500	360
NA 155.160.200/3	2090	1500	1040	750	1290	930	640	460	1050	750	520	370	850	610	420	300
NA 155.72.200/4	2790	2010	1400	1000	1720	1240	860	620	1400	1000	700	500	1130	810	570	410
NA 155.100.200/4	2790	2010	1400	1000	1720	1240	860	620	1400	1000	700	500	1130	810	570	410
NA 196.90.200/3	3030	2180	1520	1090	1870	1340	930	670	1520	1090	760	540	1230	880	620	440
NA 196.150.200/3	3030	2180	1520	1090	1870	1340	930	670	1520	1090	760	540	1230	880	620	440
NA 196.90.200/4	4040	2910	2030	1450	2500	1790	1250	900	2030	1450	1010	730	1640	1180	820	590
NA 196.90.250/4	5390	3880	2700	1940	3320	2390	1660	1200	2700	1940	1350	970	2190	1570	1100	790
NA 196.150.250/4	5390	3880	2700	1940	3320	2390	1660	1200	2700	1940	1350	970	2190	1570	1100	790
NA 196.90.250/5	6740	4850	3380	2420	4160	2990	2080	1500	3380	2420	1690	1210	2740	1970	1370	980
NA 196.90.250/6	8090	5830	4060	2910	5000	3590	2500	1800	4060	2910	2030	1460	3290	2360	1650	1180
NA 196.90.310/6	10520	7570	5280	3780	6480	4670	3250	2340	5280	3780	2640	1900	4270	3070	2140	1500
NA 196.150.310/6	10520	7570	5280	3780	6480	4670	3250	2340	5280	3780	2640	1900	4270	3070	2140	1500

## Selection table

### Power based life selection table

Order code	Life $L_h$ [h]															
	1000				5000				10000				20000			
	Speed $n$ [1/min]															
	50	150	500	1500	50	150	500	1500	50	150	500	1500	50	150	500	1500
	Power $P_B$ [kW]															
NA 44.25.50/3	0,2	0,5	1,2	2,5	0,1	0,3	0,7	1,6	0,1	0,3	0,6	1,3	0,09	0,2	0,5	0,9
NA 44.25.50/4	0,3	0,68	1,6	3,5	0,2	0,4	1,0	2,2	0,16	0,35	0,79	1,7	0,13	0,28	0,63	1,4
NA 44.25.70/6	0,8	1,6	3,8	8,2	0,5	1,0	2,3	5,0	0,4	0,8	1,9	4,1	0,3	0,7	1,5	3,3
NA 74.36.70/3	0,6	1,3	3,0	6,4	0,4	0,8	1,8	3,9	0,3	0,6	1,5	3,1	0,2	0,5	1,2	2,5
NA 74.36.90/3	0,9	1,9	4,3	9,3	0,5	1,1	2,7	5,8	0,4	0,9	2,1	4,7	0,4	0,8	1,8	3,8
NA 74.70.90/3	0,9	1,9	4,3	9,3	0,5	1,1	2,7	5,8	0,4	0,9	2,1	4,7	0,4	0,8	1,8	3,8
NA 74.36.90/4	1,2	2,5	5,8	12,4	0,7	1,5	3,6	7,7	0,6	1,2	2,9	6,1	0,5	1,0	2,4	5,0
NA 74.36.90/5	1,4	3,1	7,2	15,6	0,9	1,9	4,5	9,7	0,7	1,6	3,7	7,9	0,6	1,3	3,0	6,4
NA 74.120.120/3	1,2	2,6	6,0	13,0	0,7	1,6	3,7	8,0	0,6	1,3	3,0	6,4	0,5	1,1	2,5	5,3
NA 74.36.120/4	1,6	3,5	8,1	17,4	1,0	2,2	5,0	10,7	0,8	1,7	4,0	8,6	0,7	1,4	3,3	7,1
NA 74.70.120/4	1,6	3,5	8,1	17,4	1,0	2,2	5,0	10,7	0,8	1,7	4,0	8,6	0,7	1,4	3,3	7,1
NA 74.36.150/4	2,1	4,8	10,8	22,8	1,3	2,8	6,5	14,1	1,1	2,3	5,3	11,5	0,9	1,9	4,3	9,3
NA 74.70.150/4	2,1	4,8	10,8	22,8	1,3	2,8	6,5	14,1	1,1	2,3	5,3	11,5	0,9	1,9	4,3	9,3
NA 74.120.150/4	2,1	4,8	10,8	22,8	1,3	2,8	6,5	14,1	1,1	2,3	5,3	11,5	0,9	1,9	4,3	9,3
NA 101.56.100/3	2,1	4,5	10,4	22,3	1,3	2,8	6,4	13,8	1,0	2,2	5,2	11,1	0,8	1,8	4,2	9,1
NA 101.56.120/3	2,7	5,8	13,3	28,7	1,6	3,5	8,2	17,7	1,3	2,9	6,6	14,4	1,1	2,3	5,4	11,6
NA 101.90.120/3	2,7	5,8	13,3	28,7	1,6	3,5	8,2	17,7	1,3	2,9	6,6	14,4	1,1	2,3	5,4	11,6
NA 101.56.120/4	3,6	7,7	17,8	38,8	2,2	4,7	10,9	23,7	1,8	3,8	8,9	19,2	1,4	3,1	7,2	15,5
NA 101.120.140/3	3,3	7,0	16,3	35,2	2,0	4,3	10,0	21,7	1,6	3,5	8,2	17,6	1,3	2,9	6,6	14,3
NA 101.56.140/4	4,3	9,4	21,8	46,9	2,7	5,8	13,4	28,9	2,2	4,7	10,9	23,4	1,8	3,8	8,8	19,9
NA 101.90.140/4	4,3	9,4	21,8	46,9	2,7	5,8	13,4	28,9	2,2	4,7	10,9	23,4	1,8	3,8	8,8	19,9
NA 101.160.160/3	3,9	8,3	19,3	42,2	2,4	5,1	11,9	25,6	1,9	4,2	9,6	20,7	1,6	3,4	7,9	16,8
NA 101.56.160/4	5,1	11,1	25,8	55,4	3,2	6,8	15,9	34,2	2,6	5,5	12,9	27,8	2,1	4,5	10,5	22,5
NA 101.90.160/4	5,1	11,1	25,8	55,4	3,2	6,8	15,9	34,2	2,6	5,5	12,9	27,8	2,1	4,5	10,5	22,5
NA 101.120.160/4	5,1	11,1	25,8	55,4	3,2	6,8	15,9	34,2	2,6	5,5	12,9	27,8	2,1	4,5	10,5	22,5
NA 134.64.140/3	4,7	10,1	23,3	50,2	2,9	6,2	14,4	31,1	2,3	5,0	11,7	25,1	2,0	4,1	9,5	20,4
NA 134.90.140/3	4,7	10,1	23,3	50,2	2,9	6,2	14,4	31,1	2,3	5,0	11,7	25,1	2,0	4,1	9,5	20,4
NA 134.64.160/3	5,6	12,1	28,1	60,3	3,4	7,4	17,2	37,2	2,8	6,0	14,0	30,1	2,3	4,9	11,4	24,5
NA 134.90.160/3	5,6	12,1	28,1	60,3	3,4	7,4	17,2	37,2	2,8	6,0	14,0	30,1	2,3	4,9	11,4	24,5
NA 134.120.160/3	5,6	12,1	28,1	60,3	3,4	7,4	17,2	37,2	2,8	6,0	14,0	30,1	2,3	4,9	11,4	24,5
NA 134.64.160/4	7,5	16,1	37,4	80,4	4,6	9,9	23,0	49,6	3,7	8,0	18,7	40,4	3,0	6,5	15,2	32,7
NA 134.90.160/4	7,5	16,1	37,4	80,4	4,6	9,9	23,0	49,6	3,7	8,0	18,7	40,4	3,0	6,5	15,2	32,7
NA 155.72.160/3	8,3	17,9	41,4	89,5	5,1	11,0	25,1	55,0	4,1	9,0	20,4	44,0	3,3	7,2	16,7	36,1
NA 155.72.160/4	11,9	24,3	56,5	121,7	7,0	15,0	34,8	75,4	5,7	12,2	28,3	60,9	4,6	9,9	23,0	49,6
NA 155.100.160/3	8,3	17,9	41,4	89,5	5,1	11,0	25,1	55,0	4,1	9,0	20,4	44,0	3,3	7,2	16,7	36,1
NA 155.72.180/3	9,7	20,9	48,7	103,6	6,0	12,9	29,8	64,4	4,9	10,4	24,1	51,8	3,9	8,5	19,9	42,4
NA 155.100.180/3	9,7	20,9	48,7	103,6	6,0	12,9	29,8	64,4	4,9	10,4	24,1	51,8	3,9	8,5	19,9	42,4
NA 155.72.180/4	12,9	28,0	64,9	139,8	8,0	17,3	39,8	86,4	6,8	14,0	32,5	69,1	5,2	11,3	26,2	56,5
NA 155.160.200/3	10,9	23,6	54,4	117,8	6,8	14,6	33,5	72,2	5,5	11,8	27,2	58,1	4,4	9,6	22,0	47,1
NA 155.72.200/4	14,6	31,6	73,3	157,0	9,0	19,5	45,0	97,4	7,3	15,7	36,6	78,5	5,9	12,7	29,8	64,4
NA 155.100.200/4	14,6	31,6	73,3	157,0	9,0	19,5	45,0	97,4	7,3	15,7	36,6	78,5	5,9	12,7	29,8	64,4
NA 196.90.200/3	15,9	34,2	79,6	171,2	9,8	21,0	48,7	105,2	8,0	17,1	39,8	84,8	6,4	13,8	32,5	69,1
NA 196.150.200/3	15,9	34,2	79,6	171,2	9,8	21,0	48,7	105,2	8,0	17,1	39,8	84,8	6,4	13,8	32,5	69,1
NA 196.90.200/4	21,1	45,7	106,3	227,7	13,1	28,1	65,4	141,3	10,6	22,8	52,8	114,6	8,6	18,5	42,9	92,6
NA 196.90.250/4	28,2	60,9	141,3	304,6	17,4	37,5	86,9	188,4	14,1	30,5	70,7	152,3	11,5	24,7	57,6	124,1
NA 196.150.250/4	28,2	60,9	141,3	304,6	17,4	37,5	86,9	188,4	14,1	30,5	70,7	152,3	11,5	24,7	57,6	124,1
NA 196.90.250/5	35,3	76,2	176,9	380,0	21,8	47,0	108,9	235,5	17,7	38,0	88,5	190,0	14,3	30,9	71,7	153,9
NA 196.90.250/6	42,3	91,5	212,5	456,9	26,2	56,4	130,9	282,6	21,3	45,7	106,3	229,3	17,2	37,1	86,4	185,3
NA 196.90.310/6	55,1	118,9	276,4	593,6	33,9	73,3	170,1	367,4	27,6	59,4	138,2	298,3	22,3	48,2	112,0	241,8
NA 196.150.310/6	55,1	118,9	276,4	593,6	33,9	73,3	170,1	367,4	27,6	59,4	138,2	298,3	22,3	48,2	112,0	241,8

## Dimensions NA 280 - NAS 600 (heavy series)

### PK coupling (A1, A2, A4, A7)

INKOMA-PK coupling is available in the following versions:

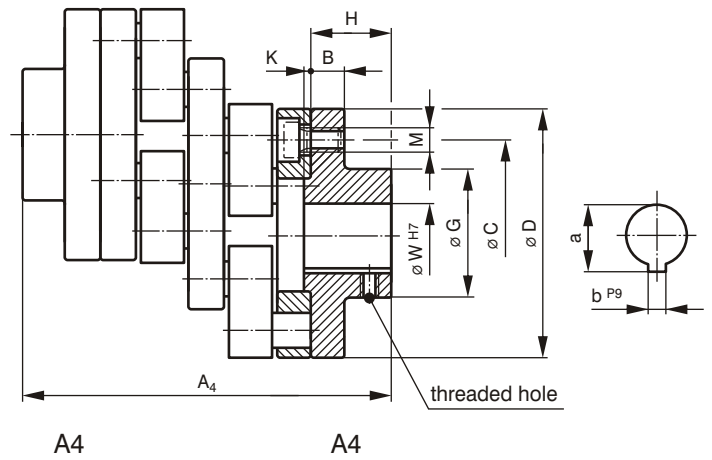
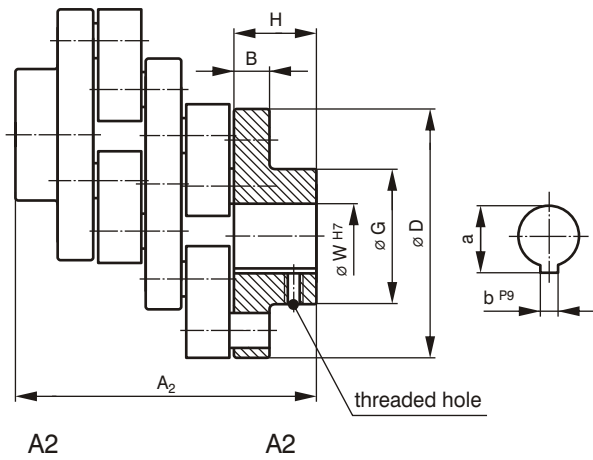
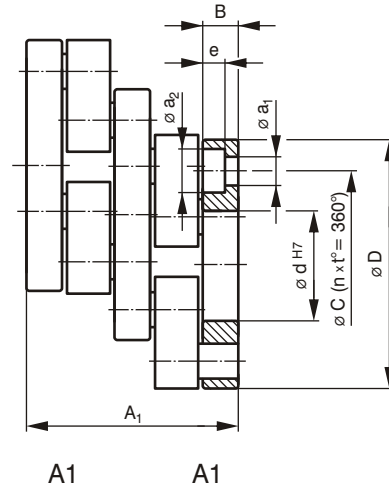
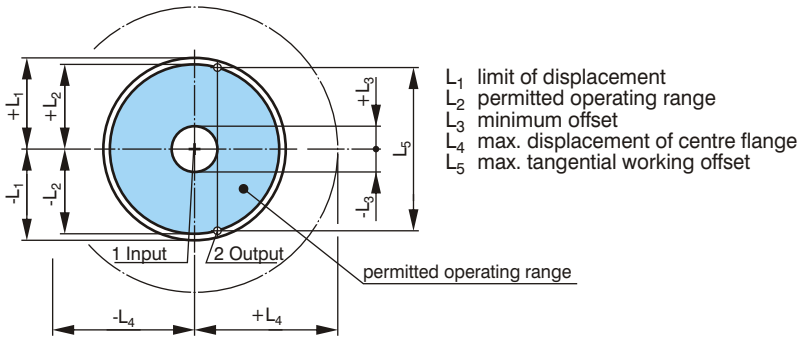

$$A4 = A1 + GFL$$

For missing dimensions and designations for GFL see page 16.

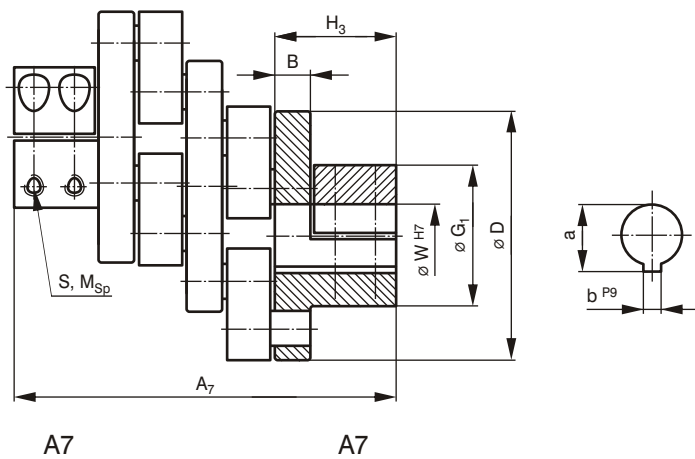

Order code	Dimensions [mm]																
	A <sub>1</sub>	A <sub>2</sub>	A <sub>4</sub>	A <sub>7</sub>	B	C	D	G	H	K	W	a	a <sub>1</sub>	a <sub>2</sub>	b	d	e
NA 280.150.350/4	280	414	510	1)	48	272	350	180	115	5	80	85,4	22	33	22	180	26
NA 280.150.350/5	280	414	510	1)	48	272	350	180	115	5	80	85,4	22	33	22	180	26
NA 280.150.400/5	280	454	550	1)	48	320	400	200	135	5	80	85,4	22	33	22	200	26
NA 280.150.400/6	280	454	550	1)	48	320	400	200	135	5	80	85,4	22	33	22	200	26
NA 280.150.500/6	280	454	550	1)	48	420	500	200	135	5	100	106,4	22	33	28	200	26
NAS 460.230.425/3	460	1)	1)	1)	80	300	425	1)	1)	1)	1)	1)	1)	1)	1)	200	1)
NAS 460.230.480/3	460	1)	1)	1)	80	350	480	1)	1)	1)	1)	1)	1)	1)	1)	210	1)
NAS 460.230.480/4	460	1)	1)	1)	80	350	480	1)	1)	1)	1)	1)	1)	1)	1)	210	1)
NAS 460.230.560/4	460	1)	1)	1)	80	432	560	1)	1)	1)	1)	1)	1)	1)	1)	220	1)
NAS 460.230.560/5	460	1)	1)	1)	80	432	560	1)	1)	1)	1)	1)	1)	1)	1)	220	1)
NAS 460.230.620/6	460	1)	1)	1)	80	490	620	1)	1)	1)	1)	1)	1)	1)	1)	250	1)
NAS 600.320.580/3	600	1)	1)	1)	100	400	580	1)	1)	1)	1)	1)	1)	1)	1)	220	1)
NAS 600.320.700/3	600	1)	1)	1)	100	520	700	1)	1)	1)	1)	1)	1)	1)	1)	300	1)
NAS 600.320.680/4	600	1)	1)	1)	100	500	680	1)	1)	1)	1)	1)	1)	1)	1)	300	1)

Order code	Dimensions [mm]					Mounting holes			Betriebsdaten		Mass <sup>2)</sup> [kg]	CAD-No.:
	limit of displacement	permitted operating range	minimum offset	max. displacement of centre flange	max. tangential working offset	Thread	Number	Hole pitch	Torque	Inertia <sup>2)</sup>		
	L <sub>1</sub>	L <sub>2</sub>	L <sub>3</sub>	L <sub>4</sub>	L <sub>5</sub>	M	n	t [°]	T <sub>stat.</sub> [Nm]	J [kg cm <sup>2</sup> ]		
NA 280.150.350/4	150	145	37	250	270	M20	4	90	31000	20000	103	32001
NA 280.150.350/5	150	145	37	250	270	M20	5	72	39000	21200	109	32004
NA 280.150.400/5	150	145	37	275	270	M20	5	72	46000	34000	136	32007
NA 280.150.400/6	150	145	37	275	270	M20	6	60	55000	34500	138	32010
NA 280.150.500/6	150	145	37	325	270	M20	6	60	73000	80100	221	32013
NAS 460.230.425/3	230	220	56	328	414	1)	3	120	100000	69800	253	32101
NAS 460.230.480/3	230	220	56	355	414	1)	3	120	115000	109800	320	32104
NAS 460.230.480/4	230	220	56	355	414	1)	4	90	150000	115000	335	32107
NAS 460.230.560/4	230	220	56	395	414	1)	4	90	190000	202500	453	32110
NAS 460.230.560/5	230	220	56	395	414	1)	5	72	238000	209300	468	32113
NAS 460.230.620/6	230	220	56	425	414	1)	6	60	325000	317000	567	32116
NAS 600.320.580/3	320	304	80	450	575	1)	3	120	275000	285300	593	32201
NAS 600.320.700/3	320	304	80	510	575	1)	3	120	355000	580000	800	32204
NAS 600.320.680/4	320	304	80	500	575	1)	4	90	450000	530000	768	32207

<sup>1)</sup> Hub length, diameter, bore and fixing screws to customer requirements

<sup>2)</sup> for version A1

Axial freedom ± 4 mm

## Ordering example

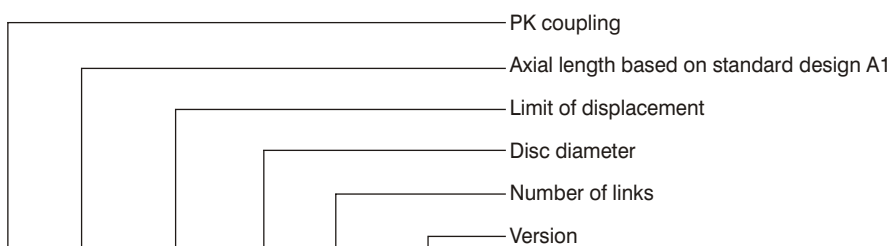

**NA 280 . 150 . 350 / 4 - A2-A4**

## Dimensions GLK, GL (light series, plain bearing)

### PK coupling

(GL) K: Centre disc and links in plastic  
Outer disc in aluminium

Grubscrew to DIN 916 or with keyway to BS 4235 (DIN 6885/1).

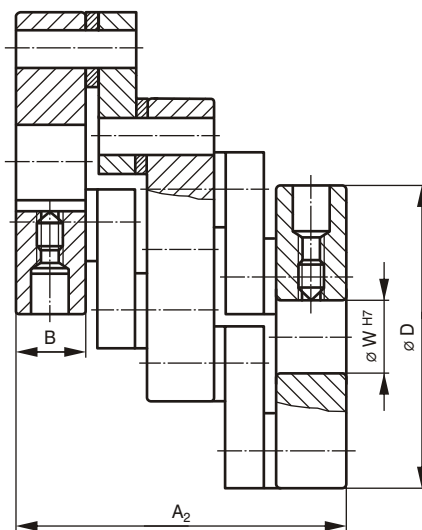
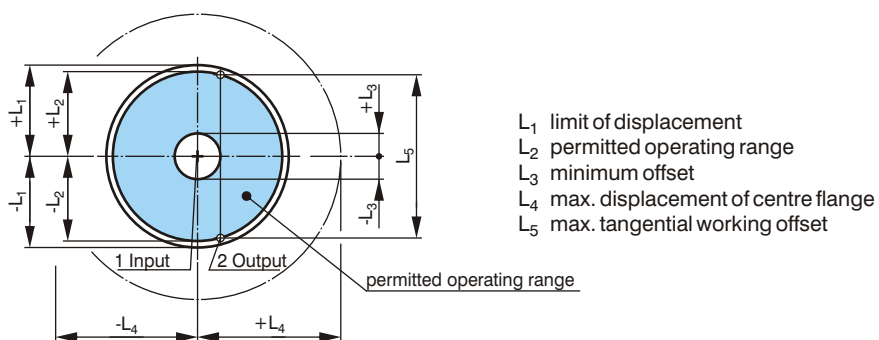

### Ordering example:

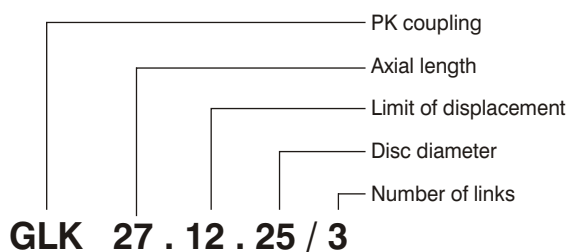

Order code	Dimensions [mm]									Operational data		Mass [kg]	CAD-No.:
	A <sub>2</sub>	B	D	W	limit of displacement L <sub>1</sub>	permitted operating range L <sub>2</sub>	minimum offset L <sub>3</sub>	max. displacement of centre flange L <sub>4</sub>	max. tangential working offset L <sub>5</sub>	T <sub>stat.</sub> [Nm]	J [kg cm <sup>2</sup> ]		
GLK 27.12.25/3 <sup>1)</sup>	27	5,4	25	8	12	11	3	19	21,6	1,7	0,02	0,023	33001
GLK 58.26.48/3 <sup>1)</sup>	58	11,5	48	16	26	25	5	37	46,8	8,6	0,56	0,174	33005
GL 42.30.40/3 <sup>1)</sup>	42	9,4	40	10	30	28,5	7,5	35	54	12,8	0,27	0,130	33011
GL 65.26.48/3 <sup>1)</sup>	65	15	48	16	26	25	6,5	37	46,8	38,0	0,69	0,215	33021

<sup>1)</sup> not fixed axially

Axial freedom +2mm

Order code	Life L <sub>h</sub> [h]											
	500				1000				5000			
	Speed n [1/min]											
	50	150	500	1500	50	150	500	1500	50	150	500	1500
	Torque T [Nm]											
GLK 27.12.25/3	1,7	1,7	1,1	0,35	1,8	1,8	0,6	0,25	1,4	0,9	0,3	0,15
GLK 58.26.48/3	8	7	5	1,8	6	5	3	1,3	5	4	1,6	0,8
GL 42.30.40/3	12	12	8,8	2,8	10	10	4,8	2	8	6	2,4	1,2
GL 65.26.48/3	38	32	9	3,6	33	20	7,2	2,7	25	11,7	3,6	1,3

Order code	Life L <sub>h</sub> [h]											
	500				1000				5000			
	Speed n [1/min]											
	50	150	500	1500	50	150	500	1500	50	150	500	1500
	Power P <sub>B</sub> [W]											
GLK 27.12.25/3	9	27	56	54	9	27	31	38	8	14	15	22
GLK 58.26.48/3	42	110	260	280	46	140	165	200	41	72	78	115
GL 42.30.40/3	63	190	460	430	72	220	280	300	64	112	120	176
GL 65.26.48/3	190	500	490	560	190	300	370	410	160	180	180	200

## Dimensions for GFL

### GFL - separable flange

For version A4.

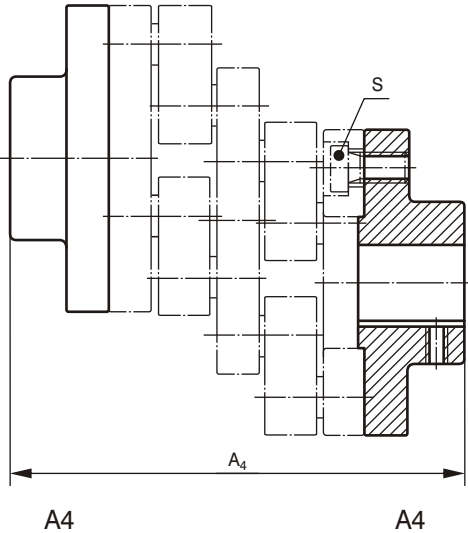
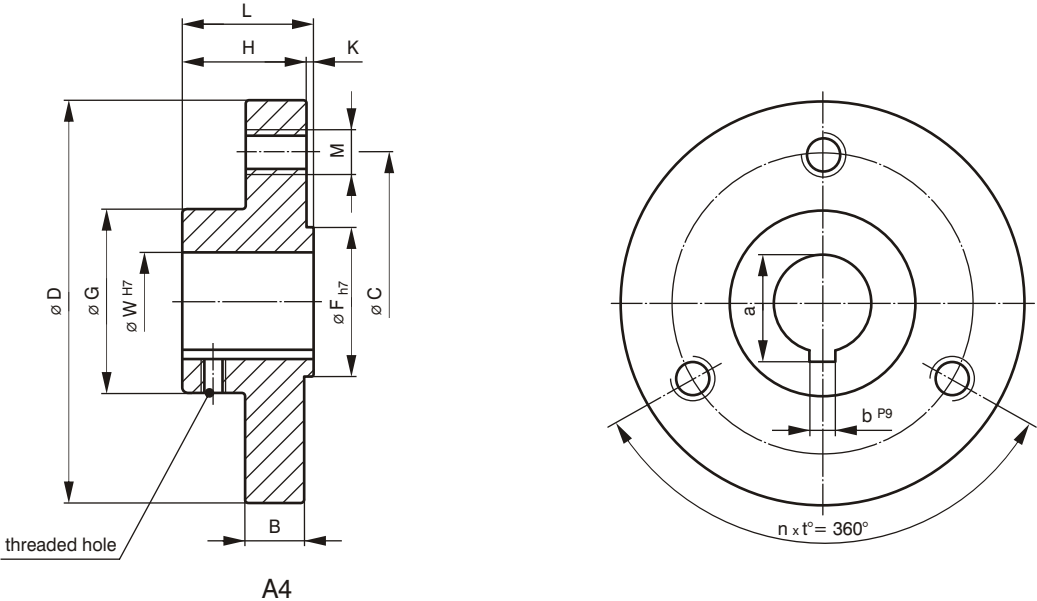

### Ordering example:

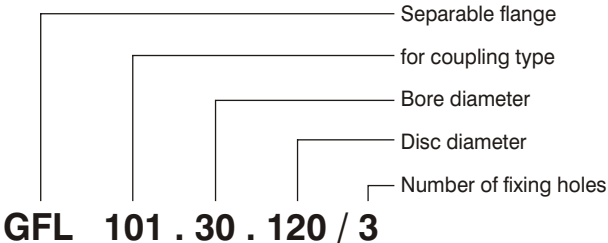



Order code	Dimension [mm]												Mounting holes			Inertia J [kg cm <sup>2</sup> ]	Mounting screws <sup>3)</sup> S	Mass [kg]	CAD-No.:
	B	C	D	F	G	H	K	L	W <sup>1)</sup>	W <sub>max.</sub>	a <sup>2)</sup>	b <sup>2)</sup>	Thread M	Number n	Hole pitch t [°]				
GFL 44.14.50/3	8	35	50	22	28	20	2	22	14	18	16,2	5	M6	3	120	0,5	3xM6x10	0,16	34001
GFL 44.14.50/4	8	35	50	22	28	20	2	22	14	18	16,2	5	M6	4	90	0,5	4xM6x10	0,16	34003
GFL 44.16.70/6	8	56	70	25	35	20	2	22	16	22	18,2	5	M6	6	60	1,9	6xM6x10	0,30	34002
GFL 74.16.70/3	10,5	48	70	25	35	20	2	22	16	22	18,3	5	M8	3	120	2,3	3xM8x14	0,36	34101
GFL 74.25.90/3	10,5	70	90	45	55	37	3	40	25	40	28,3	8	M8	3	120	9,7	3xM8x14	0,89	34102
GFL 74.25.90/4	10,5	70	90	45	55	37	3	40	25	40	28,3	8	M8	4	90	9,7	4xM8x14	0,89	34103
GFL 74.25.90/5	10,5	70	90	45	55	37	3	40	25	40	28,3	8	M8	5	72	9,7	5xM8x14	0,89	34107
GFL 74.30.120/3	10,5	98	120	50	60	42	3	45	30	45	33,3	8	M8	3	120	29	3xM8x14	1,4	34104
GFL 74.30.120/4	10,5	98	120	50	60	42	3	45	30	45	33,3	8	M8	4	90	29	4xM8x14	1,4	34105
GFL 74.35.150/4	10,5	128	150	60	70	42	3	45	35	50	38,3	10	M8	4	90	62	4xM8x14	2,1	34106
GFL 101.30.100/3	15,5	70	100	40	55	37	3	40	30	40	33,3	8	M12	3	120	16	3xM12x20	1,15	34301
GFL 101.30.120/3	15,5	90	120	50	65	42	3	45	30	45	33,3	8	M12	3	120	34	3xM12x20	1,8	34302
GFL 101.30.120/4	15,5	90	120	50	65	42	3	45	30	45	33,3	8	M12	4	90	34	4xM12x20	1,8	34303
GFL 101.35.140/3	15,5	110	140	50	70	52	3	55	35	50	38,3	10	M12	3	120	65	3xM12x20	2,5	34304
GFL 101.35.140/4	15,5	110	140	50	70	52	3	55	35	50	38,3	10	M12	4	90	65	4xM12x20	2,5	34305
GFL 101.40.160/3	15,5	130	160	60	70	52	3	55	40	55	43,3	12	M12	3	120	100	3xM12x20	3,3	34306
GFL 101.40.160/4	15,5	130	160	60	70	52	3	55	40	55	43,3	12	M12	4	90	100	4xM12x20	3,3	34307
GFL 134.35.140/3	22,5	100	140	55	70	52	3	55	35	50	38,3	10	M16	3	120	83	3xM16x30	3,2	34501
GFL 134.40.160/3	22,5	120	158	60	85	52	3	55	40	55	43,3	12	M16	3	120	140	3xM16x30	4,2	34502
GFL 134.40.160/4	22,5	120	158	60	85	52	3	55	40	55	43,3	12	M16	4	90	140	4xM16x30	4,2	34503
GFL 155.40.160/3	25	115	160	60	75	52	3	55	40	55	43,3	12	M16	3	120	146	3xM16x30	4,3	34701
GFL 155.40.160/4	25	115	160	60	75	52	3	55	40	55	43,3	12	M16	4	90	146	4xM16x30	4,3	34706
GFL 155.45.180/3	25	135	180	70	90	62	3	65	45	60	48,8	14	M16	3	120	258	3xM16x30	6,0	34702
GFL 155.45.180/4	25	135	180	70	90	62	3	65	45	60	48,8	14	M16	4	90	258	4xM16x30	6,0	34703
GFL 155.50.200/3	25	152	200	80	100	72	3	75	50	70	53,8	14	M16	3	120	420	3xM16x30	7,9	34704
GFL 155.50.200/4	25	152	200	80	100	72	3	75	50	70	53,8	14	M16	4	90	420	4xM16x30	7,9	34705
GFL 196.50.200/3	30	150	200	80	100	70	5	75	50	70	53,8	14	M20	3	120	452	3xM20x35	8,5	34801
GFL 196.50.200/4	30	150	200	80	100	70	5	75	50	70	53,8	14	M20	4	90	452	4xM20x35	8,5	34802
GFL 196.60.250/4	30	200	250	100	120	80	5	85	60	80	64,4	18	M20	4	90	1157	4xM20x35	14,0	34803
GFL 196.60.250/5	30	200	250	100	120	80	5	85	60	80	64,4	18	M20	5	72	1157	5xM20x35	14,0	34804
GFL 196.60.250/6	30	200	250	100	120	80	5	85	60	80	64,4	18	M20	6	60	1157	6xM20x35	14,0	34805
GFL 196.80.310/6	30	260	310	150	160	95	5	100	80	100	85,4	22	M20	6	60	3113	6xM20x35	24,3	34806
GFL 280.80.350/4	48	272	325	180	180	115	5	120	80	120	85,4	22	M20	4	90	5658	4xM20x50	40,4	34901
GFL 280.80.350/5	48	272	325	180	180	115	5	120	80	120	85,4	22	M20	5	72	5658	5xM20x50	40,4	34902
GFL 280.80.400/5	48	320	375	200	200	135	5	140	80	140	85,4	22	M20	5	72	10700	5xM20x50	58,2	34903
GFL 280.80.400/6	48	320	375	200	200	135	5	140	80	140	85,4	22	M20	6	60	10700	6xM20x50	58,2	34904
GFL 280.100.500/6	48	420	475	200	250	135	5	140	100	140	106,4	28	M20	6	60	27130	6xM20x50	92,1	34905

1) Dimension "W" for the bore is a preferred value

2) Values for dimension "W" with key to BS 4235 (DIN 6885/1)

3) Mounting screws are not supplied

## Dimensions for ISP-B

### ISP-B - Inkofix tension flange

For version A3.

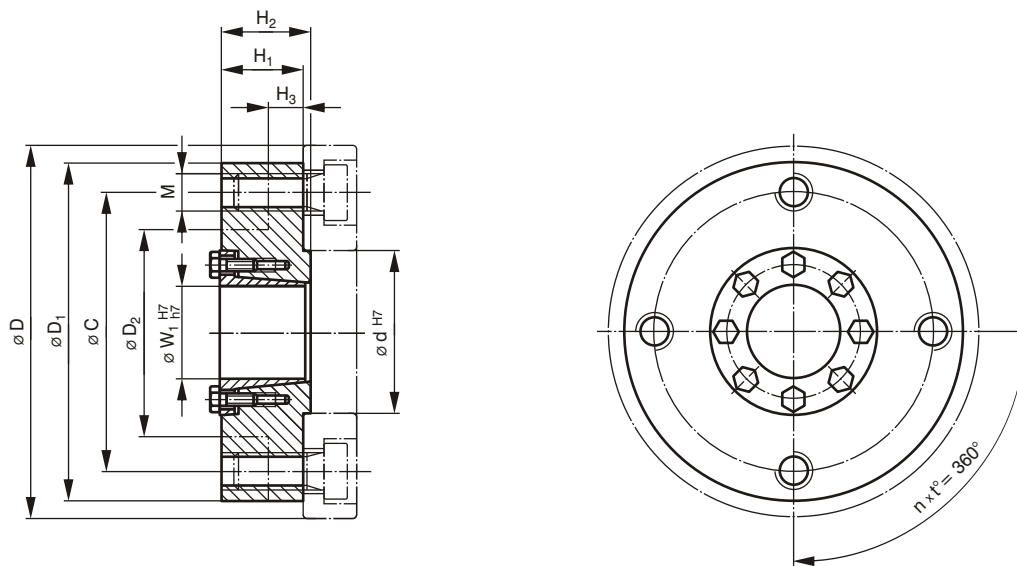

#### Explanation:

- $T_{stat.}$  = maximum transmissible torque for tension flange
- $F_{ax}$  = maximum transmissible axial force for tension flange
- $T_A$  = required tightening torque of the tension screws
- $L_1$  = limit of displacement (dependent on the size)

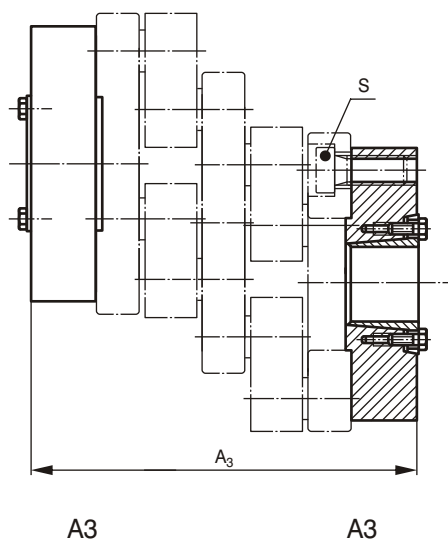

#### Ordering example:

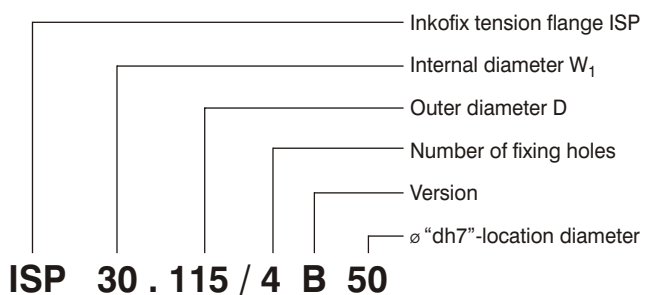

# PK couplings

Order code Coupling	Order code Tension flange	Dimensions [mm]									Mounting holes						
		d	C	D	D <sub>1</sub>	D <sub>2</sub>	H <sub>1</sub>	H <sub>2</sub>	H <sub>3</sub>	W <sub>1</sub> <sup>1)</sup>	M	n	t [°]				
NA 44.25.70/6	ISP 16.66/6B25	25	56	70	66	-	12	14	-	16	M6	6	60				
NA 74.36.70/3	ISP 16.60/3B25	25	48	70	60	-	14	16	-	16	M8	3	120				
NA 74.L <sub>1</sub> .90/3	ISP 25.82/3B45	45	70	90	82	-	14	17	-	25	M8	3	120				
NA 74.36.90/4	ISP 25.82/4B45	45	70	90	82	-	14	17	-	25	M8	4	90				
NA 74.36.90/5	ISP 25.82/5B45	45	70	90	82	-	14	17	-	25	M8	5	72				
NA 74.120.120/3	ISP 30.115/3B50	50	98	120	115	-	16	19	-	30	M8	3	120				
NA 74.L <sub>1</sub> .120/4	ISP 30.115/4B50	50	98	120	115	-	16	19	-	30	M8	4	90				
NA 74.L <sub>1</sub> .150/4	ISP 35.145/4B60	60	128	150	145	-	20	23	-	35	M8	4	90				
NA 101.56.100/3	ISP 30.90/3B40	40	70	100	90	-	20	23	-	30	M12	3	120				
NA 101.L <sub>1</sub> .120/3	ISP 30.110/3B50	50	90	120	110	-	25	28	-	30	M12	3	120				
NA 101.56.120/4	ISP 30.110/4B50	50	90	120	110	-	25	28	-	30	M12	4	90				
NA 101.120.140/3	ISP 35.130/3B50	50	110	140	130	-	30	33	-	35	M12	3	120				
NA 101.L <sub>1</sub> .140/4	ISP 35.130/4B50	50	110	140	130	-	30	33	-	35	M12	4	90				
NA 101.160.160/3	ISP 40.150/3B60	60	130	160	150	-	30	33	-	40	M12	3	120				
NA 101.L <sub>1</sub> .160/4	ISP 40.150/4B60	60	130	160	150	-	30	33	-	40	M12	4	90				
NA 134.L <sub>1</sub> .140/3	ISP 35.125/3B55	55	100	140	125	-	35	38	-	35	M16	3	120				
NA 134.L <sub>1</sub> .160/3	ISP 40.145/3B60	60	120	160	145	-	35	38	-	40	M16	3	120				
NA 134.L <sub>1</sub> .160/4	ISP 40.145/4B60	60	120	160	145	-	35	38	-	40	M16	4	90				
NA 155.L <sub>1</sub> .160/3	ISP 40.140/3B60	60	115	160	140	-	40	43	-	40	M16	3	120				
NA 155.L <sub>1</sub> .160/4	ISP 40.140/4B60	60	115	160	140	-	40	43	-	40	M16	4	90				
NA 155.L <sub>1</sub> .180/3	ISP 45.160/3B70	70	135	180	160	-	45	48	-	45	M16	3	120				
NA 155.72.180/4	ISP 45.160/4B70	70	135	180	160	-	45	48	-	45	M16	4	90				
NA 155.160.200/3	ISP 50.180/3B80	80	152	200	180	-	50	53	-	50	M16	3	120				
NA 155.L <sub>1</sub> .200/4	ISP 50.180/4B80	80	152	200	180	120	50	53	20	50	M16	4	90				
NA 196.L <sub>1</sub> .200/3	ISP 50.185/3B80	80	150	200	185	116	60	65	28	50	M20	3	120				
NA 196.90.200/4	ISP 50.185/4B80	80	150	200	185	116	60	65	28	50	M20	4	90				
NA 196.L <sub>1</sub> .250/4	ISP 60.230/4B100	100	200	250	230	-	70	75	-	60	M20	4	90				
NA 196.90.250/5	ISP 60.230/5B100	100	200	250	230	-	70	75	-	60	M20	5	72				
NA 196.90.250/6	ISP 60.230/6B100	100	200	250	230	-	70	75	-	60	M20	6	60				
NA 196.L <sub>1</sub> .310/6	ISP 80.290/6B150	150	260	310	290	-	75	80	-	80	M20	6	60				

<sup>1)</sup> Dimension "W<sub>1</sub>" for the bore is a preferred value.

Order code Coupling	Order code Tension flange	Tension screw		Operational data			Mounting screws <sup>2)</sup> S	Mass [kg]	CAD-No.:
		ISO 4017 (DIN 933) 10.9	Tightening torque T <sub>A</sub> [Nm]	Torque T <sub>stat.</sub> [Nm]	max. axial force F <sub>ax</sub> [kN]	Inertia J [kg cm <sup>2</sup> ]			
NA 44.25.70/6	ISP 16.66/6B25	6xM5x10	7	90	13	1,7	6xM6x10	0,30	53302
NA 74.36.70/3	ISP 16.60/3B25	6xM5x10	7	125	16	1,4	3xM8x14	0,29	53301
NA 74.L <sub>1</sub> .90/3	ISP 25.82/3B45	8xM5x16	7	340	27	4,9	3xM8x14	0,53	53303
NA 74.36.90/4	ISP 25.82/4B45	8xM5x16	7	340	27	4,9	4xM8x14	0,53	53304
NA 74.36.90/5	ISP 25.82/5B45	8xM5x16	7	340	27	4,9	5xM8x14	0,53	53329
NA 74.120.120/3	ISP 30.115/3B50	8xM5x16	7	680	45	21,5	3xM8x14	1,22	53308
NA 74.L <sub>1</sub> .120/4	ISP 30.115/4B50	8xM5x16	7	680	45	21,5	4xM8x14	1,22	53309
NA 74.L <sub>1</sub> .150/4	ISP 35.145/4B60	8xM6x16	12	850	49	68,0	4xM8x14	2,44	53313
NA 101.56.100/3	ISP 30.90/3B40	8xM5x16	7	830	55	10	3xM12x20	0,89	53305
NA 101.L <sub>1</sub> .120/3	ISP 30.110/3B50	8xM5x16	7	982	65	28	3xM12x20	1,73	53306
NA 101.56.120/4	ISP 30.110/4B50	8xM5x16	7	982	65	28	4xM12x20	1,73	53307
NA 101.120.140/3	ISP 35.130/3B50	8xM6x16	12	1195	68	66	3xM12x20	2,90	53311
NA 101.L <sub>1</sub> .140/4	ISP 35.130/4B50	8xM6x16	12	1195	68	66	4xM12x20	2,90	53312
NA 101.160.160/3	ISP 40.150/3B60	8xM6x16	12	1920	96	117	3xM12x20	3,90	53317
NA 101.L <sub>1</sub> .160/4	ISP 40.150/4B60	8xM6x16	12	1920	96	117	4xM12x20	3,90	53318
NA 134.L <sub>1</sub> .140/3	ISP 35.125/3B55	8xM6x16	12	1385	79	65	3xM16x30	3,10	53310
NA 134.L <sub>1</sub> .160/3	ISP 40.145/3B60	8xM6x16	12	2220	111	119	3xM16x30	4,19	53315
NA 134.L <sub>1</sub> .160/4	ISP 40.145/4B60	8xM6x16	12	2220	111	119	4xM16x30	4,19	53316
NA 155.L <sub>1</sub> .160/3	ISP 40.140/3B60	8xM6x16	12	2460	123	118	3xM16x30	4,44	53314
NA 155.L <sub>1</sub> .160/4	ISP 40.140/4B60	8xM6x16	12	2460	123	118	4xM16x30	4,44	53330
NA 155.L <sub>1</sub> .180/3	ISP 45.160/3B70	10xM6x16	12	3000	133	226	3xM16x30	6,54	53319
NA 155.72.180/4	ISP 45.160/4B70	10xM6x16	12	3000	133	226	4xM16x30	6,54	53320
NA 155.160.200/3	ISP 50.180/3B80	10xM6x20	12	4100	164	402	3xM16x30	9,21	53321
NA 155.L <sub>1</sub> .200/4	ISP 50.180/4B80	10xM6x20	12	4100	164	402	4xM16x30	9,21	53322
NA 196.L <sub>1</sub> .200/3	ISP 50.185/3B80	10xM6x20	12	5200	208	538	3xM20x35	11,73	53323
NA 196.90.200/4	ISP 50.185/4B80	10xM6x20	12	5200	208	538	4xM20x35	11,73	53324
NA 196.L <sub>1</sub> .250/4	ISP 60.230/4B100	10xM6x20	12	9800	327	1500	4xM20x35	21,27	53325
NA 196.90.250/5	ISP 60.230/5B100	10xM6x20	12	9800	327	1500	5xM20x35	21,27	53326
NA 196.90.250/6	ISP 60.230/6B100	10xM6x20	12	9800	327	1500	6xM20x35	21,27	53327
NA 196.L <sub>1</sub> .310/6	ISP 80.290/6B150	10xM8x25	32	13600	340	4061	6xM20x35	35,90	53328

<sup>2)</sup> Mounting screws are not supplied

## Questionnaire for quotation purpose

Company: .....

Department: ..... Contact: .....

Date: ..... Tel.: ..... Fax.: .....

Address: .....

Project: .....

### Operational data:

Nature of loading				
	P [kW]	T [Nm]	n [1/min]	ED [%]
1				
2				
3				

### Type of loading:

steady     variable     shock     growing     vibration

### Drive:

electric motor     internal combustion engine     other:.....

Duty: .....h/d    Required life: .....h

### Operating conditions:

Environmental temperature from: .....°C to .....°C

dry     moist     dust (state material): .....

Other unstated operational conditions: .....

### Details of installation:

#### shaft offset:

constant  $L_2 =$  .....mm

variable between  $+L_2 =$  .....mm and  $-L_2 =$  .....mm

$L_3 =$  minimum offset

Note: Co-axial shaft situations must be avoided.  
(INKOMA-Lineflex coupling can operate in co-axial situations.)

#### Angular misalignment:

constant  $\alpha =$  .....°

variable between  $+\alpha =$  .....° and  $-\alpha =$  .....°

#### Type of offset:

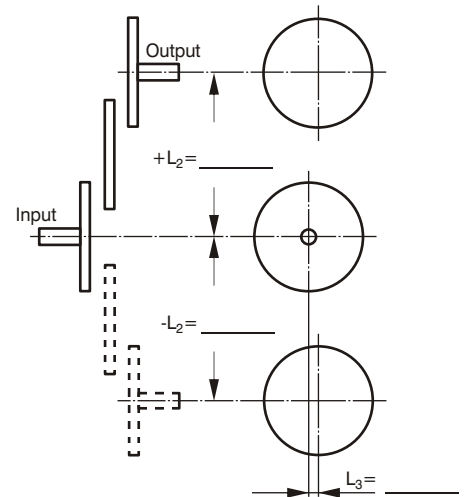
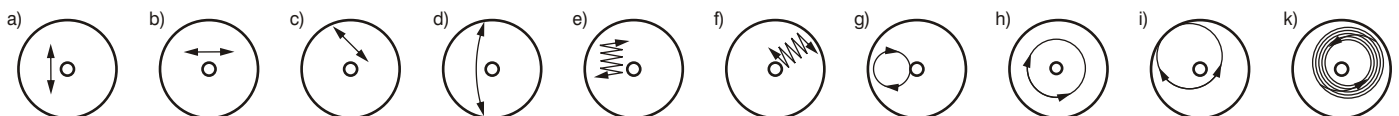

Requirements: Prototype: .....

Annual requirement: ..... In deliveries of: .....

Required delivery: .....